

Patio Heater

Model: PH08-SA, PH08-SSA
Item #: 60804

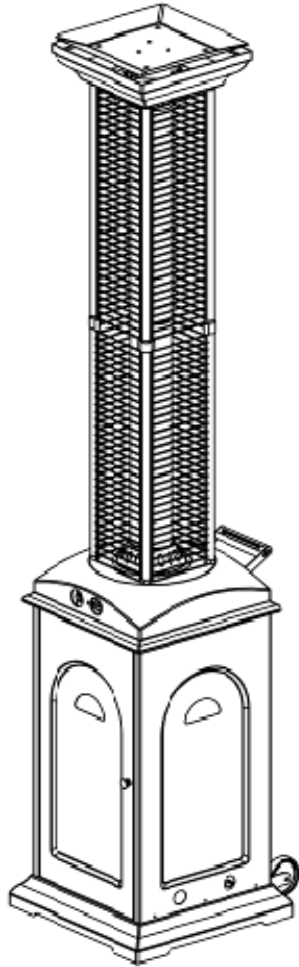

WARNING: For outdoor use only.

FOR YOUR SAFETY

If you smell gas:

1. Shut off gas to the appliance.
2. Extinguish any open flame.
3. If odor continues, immediately call gas supplier.

FOR YOUR SAFETY

Do not store or use gasoline or other flammable vapors or liquids in the vicinity of this or any other appliance. An LP-cylinder not connected for use shall not be stored in the vicinity of this or any other appliance.



Conforms to ANSI
STD Z83.26a -2008
Certified to CSA
STD 2.37a -2008

Intertek

3177588

Instruction Manual & Parts List

INSTALLER: Please leave this manual for the consumer.

CONSUMER: Please retain this manual for future reference.

MANUFACTURER: Changzhou Wellife Furnace Co., Ltd.

-

1 -

Tools and parts needed for assembly



DANGER



CARBON MONOXIDE HAZARD

This appliance can produce carbon monoxide which has no odor.

Using it in an enclosed space can kill you.

Never use this appliance in an enclosed space such as a camper, tent, car or home.

WARNING: Improper installation, adjustment, alteration, service or maintenance can cause injury or property damage. Read the installation, operating and maintenance instructions thoroughly before installing or servicing this equipment.

WARNING :

For Outdoor Use Only

LPG Cylinders to be used must be constructed and marked in accordance with US DOT specifications.

Storage of the heater indoors is permissible only if the gas cylinder is turned off and removed.

NOTE:

Use only 20lb LP-Gas tank with size of 18.1in / 46cm(Height)*12.5in / 32cm (Width).

Do not use if the environment temperature is below 40 degrees F / 4.4 degrees C.

Tools needed:

- Open end wrench 10 & 13mm (included)

NOT included:

- Adjustable opening wrench 8" long
- Phillips screwdriver w/ medium blade
- Spray bottle of soapy solution for leak testing

NOTE: PLEASE READ THE FOLLOWING SAFETY RULES

WARNING:

This heater must only be used outdoors. Using this product in an enclosed area may cause injury, death or property damage.

Only use in a well-ventilated space. Do not use in a building, garage, or any other enclosed area.

Read the instructions before use. This heater must be installed in accordance with local codes or, in the absence of local codes, with the National Fuel Code, ANSI Z223.1. If applicable, the heater, when installed, must be electrically grounded in accordance with local codes or, in the absence of local codes, with The National Electrical Code, ANSI/NFPA70.

Do not use the heater in an explosive atmosphere. Keep the heater away from areas where gasoline or other flammable liquids or vapors are stored.

Prior to use, check for damaged parts such as hoses, regulators, pilot or burner.

Turn off and disconnect LPG cylinder before moving the heater.

Do not attempt to alter this heater in any manner. **EXAMPLE:** Using the heater without the top canopy reflector or radiant screen.

Do not use this heater in basements or below ground level. It must always be placed on a solid and level surface.

Always ensure there is ample fresh air ventilation. For outdoor use **ONLY**.

Never replace or substitute the regulator with any regulator other than the factory suggested replacement.

Do not clean the heater with cleaners that are combustible or corrosive.

Do not paint radiant screen, control panel, or top canopy reflector.

All leak tests should be done with a soapy solution. **NEVER USE AN OPEN FLAME TO CHECK FOR LEAKS.**

The LPG cylinder should be turned off when the heater is not in use.

At least once a year, the unit should be inspected for the presence of spiders, spider webs or other insects.

CHECK THE HEATER IMMEDIATELY IF ANY OF THE FOLLOWING EXIST:

1. The smell of gas in conjunction with extreme yellow colored tips of the burner flames.
2. The heater does not reach temperature.
3. The burner makes a popping noise during use (a slight popping noise is normal when the burner is extinguished after using).

Children and adults should be aware of the hazards of high surface temperature, and should stay away to avoid burns or clothing ignition.

Young children should be carefully supervised when they are in the area of the heater.

Clothing or other flammable material should not be hung from the heater, or placed on or near the heater.

Any guard or other protective device removed for servicing the heater must be replaced prior to operating the heater.

Installation and repair should be done by a qualified service person. The heater should be inspected before use and cleaning may be required at least once a year, or as necessary. It is imperative that the control compartment, burner and circulating passageways of the heater are kept clean.

Keep the heater area clear of combustible materials such as gasoline and other flammable vapors and liquids.

Do not obstruct the flow of combustion and ventilation air.

Keep the ventilation opening of the LPG cylinder enclosure free and clear of debris. Storage of a heater indoors is permissible only if the LPG cylinder is turned off, disconnected and removed from the heater. Cylinders must be stored outdoors in a well-ventilated area out of the reach of children. Disconnected cylinders must have threaded valve plugs tightly installed, and must not be stored in a building, garage or any other enclosed area.

•

-

ASSEMBLY

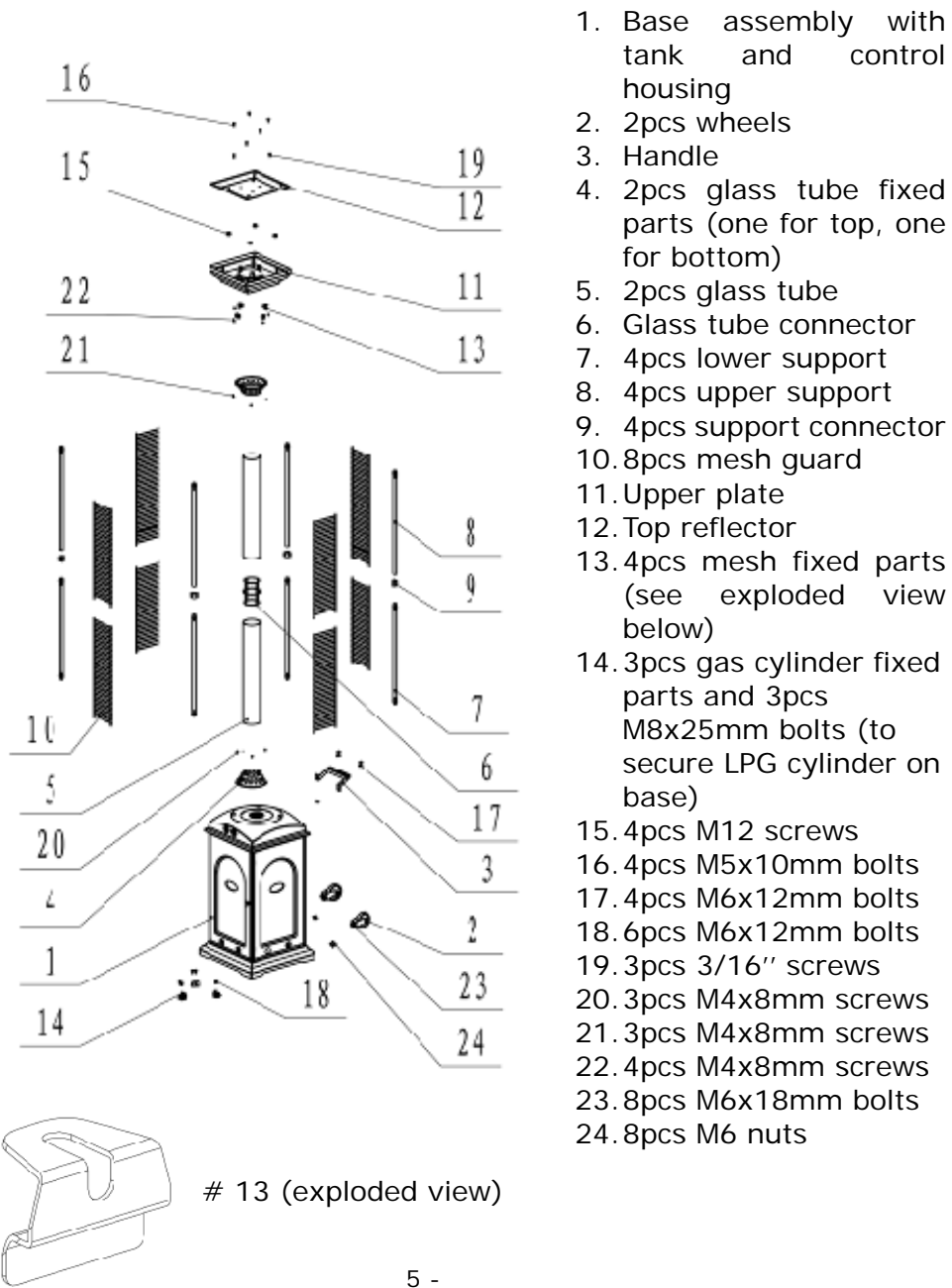

1. Base assembly with tank and control housing
2. 2pcs wheels
3. Handle
4. 2pcs glass tube fixed parts (one for top, one for bottom)
5. 2pcs glass tube
6. Glass tube connector
7. 4pcs lower support
8. 4pcs upper support
9. 4pcs support connector
10. 8pcs mesh guard
11. Upper plate
12. Top reflector
13. 4pcs mesh fixed parts (see exploded view below)
14. 3pcs gas cylinder fixed parts and 3pcs M8x25mm bolts (to secure LPG cylinder on base)
15. 4pcs M12 screws
16. 4pcs M5x10mm bolts
17. 4pcs M6x12mm bolts
18. 6pcs M6x12mm bolts
19. 3pcs 3/16" screws
20. 3pcs M4x8mm screws
21. 3pcs M4x8mm screws
22. 4pcs M4x8mm screws
23. 8pcs M6x18mm bolts
24. 8pcs M6 nuts



13 (exploded view)

WARNING: This appliance requires installation by a competent person. Proper assembly is the responsibility of the installer.

Step 1

Attach the wheels (2) to the base assembly (1) with 8pcs M6x18mm bolts (23) and 8pcs M6 nuts (24).

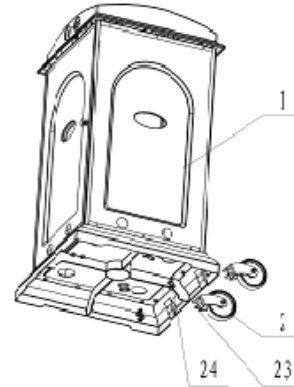

Step 2

Attach the handle (3) to the back panel of the base assembly (1) with 4pcs M6x12mm bolts (17).

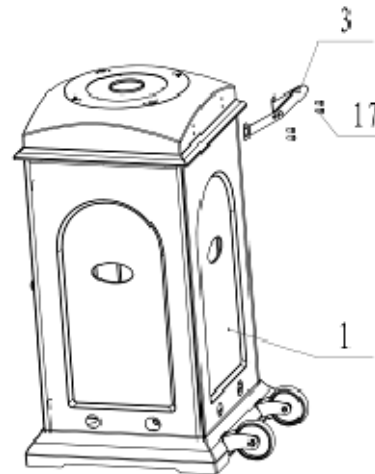

Step 3

Attach one of the glass tube fixed parts (4) on the base assembly (1) with 3pcs M4x8mm screws (20).

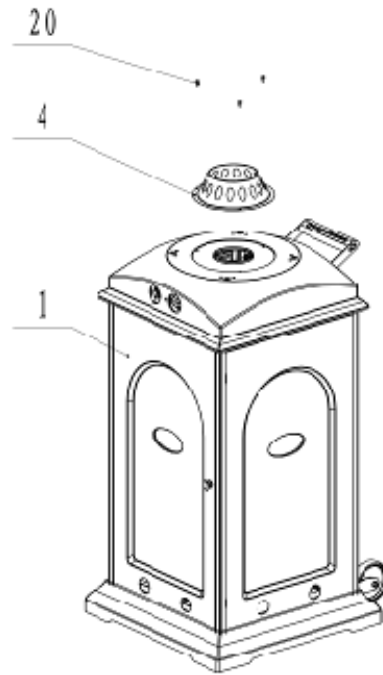
**Step 4**

Screw the 4pcs lower support (7) into the holes located on the top of the base assembly (1).

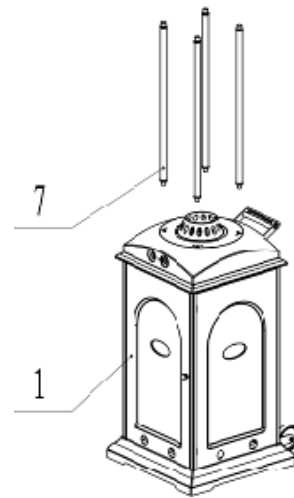

Step 5

Put the 4pcs of the support connector (9) onto the tops of the 4 lower supports (7).

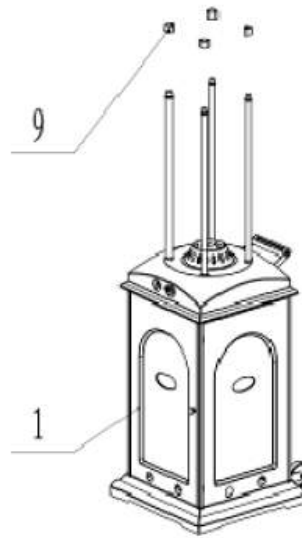

Step 6

Screw the 4 upper supports (8) onto the 4 lower supports (7).

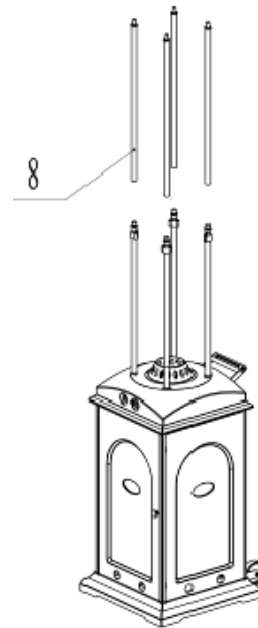

Step 7

Fit one piece of the glass tube (5) into the glass tube fixed part (4) on top of the base assembly (1). Insert the glass tube connector (6) into the glass tube piece already attached to the base assembly and then lower the second piece of glass tube over the glass tube connector.

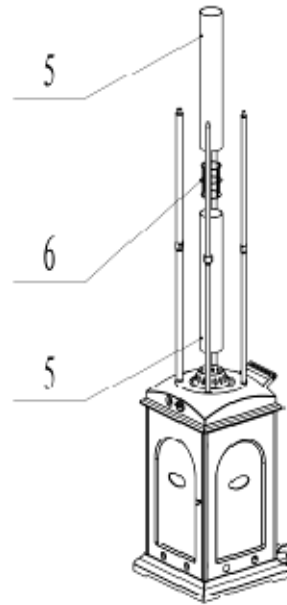
**Step 8**

Attach the other glass tube fixed part (4) to the upper plate (11) with 3 pcs M4x8mm screws (21).

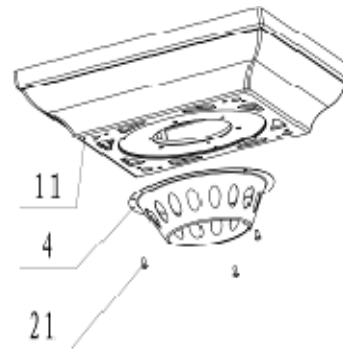

Step 9

Put the assembled upper plate from Step 8 on top of the assembled support connectors and use 4pcs M12 screws (15) to secure it.

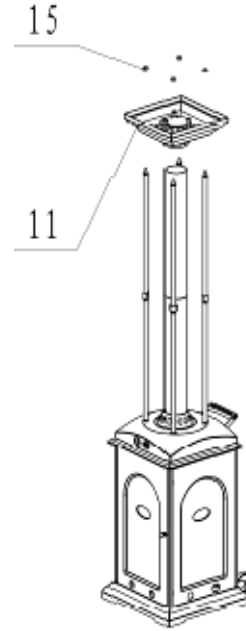
**Step 10**

Attach 4pcs mesh guard (10) on the lower support connectors. NOTE: The long side will connect with the base assembly.

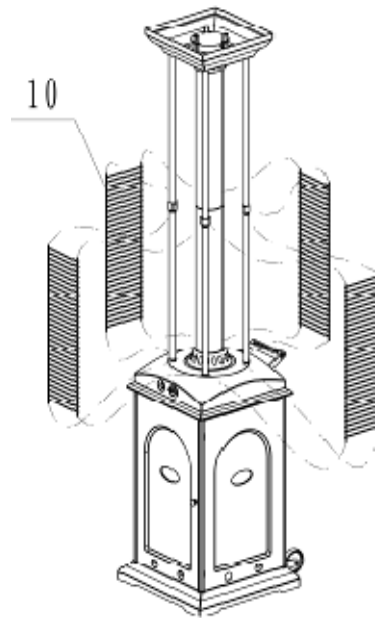

Step 11

Attach 4pcs mesh guard (10) on the upper support connectors.

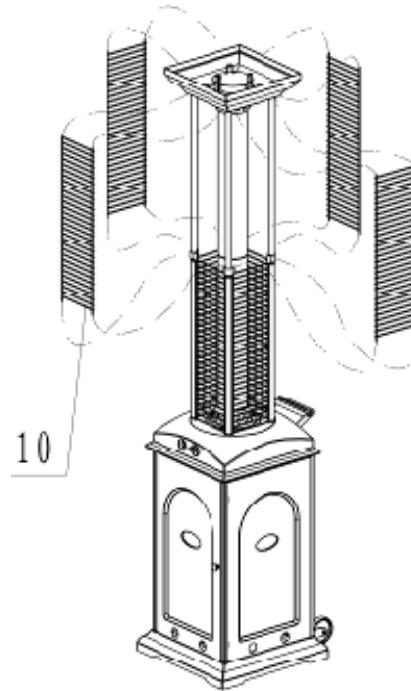
**Step 12**

Attach 4pcs mesh fixed parts (13) on the assembled upper plate with 4pcs M4x8mm screws (22).

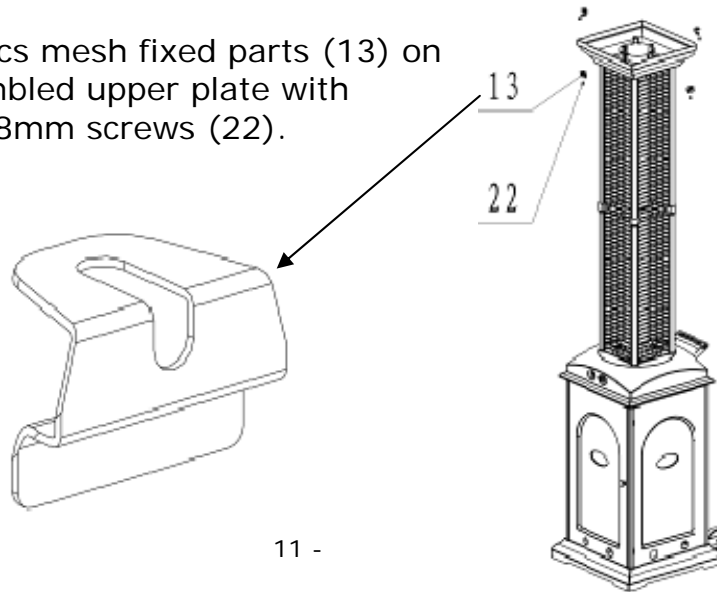

Step 13

Attach the top reflector (12) on the assembled upper plate with 3pcs 3/16" screws (19) and 4pcs M5x10mm bolts (16).

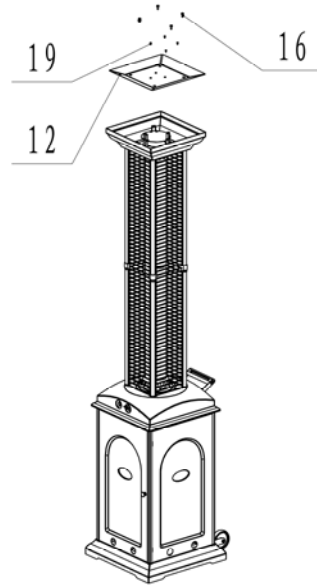

Step 14

Open the front panel of base assembly (1).
Attach 3pcs gas cylinder fixed parts (14) on the base with 6pcs M6x12mm bolts (18).

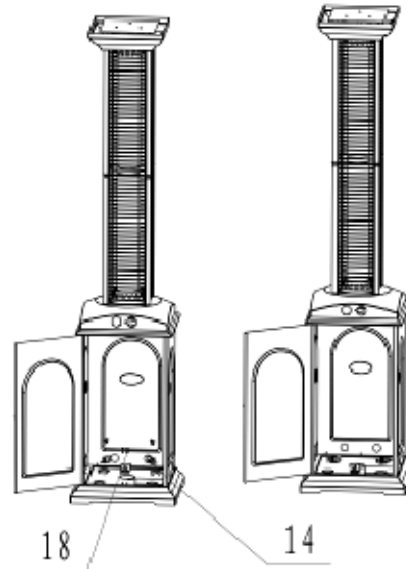

12 -

Step 15

Connect the regulator (**Preassembled with the burner**) to the LPG cylinder and hand tighten, then put gas cylinder on the base.

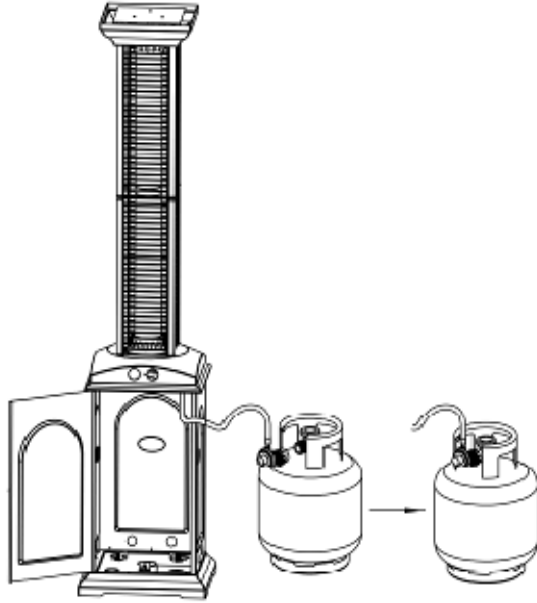

Warning: When connecting the gas cylinder and regulator, make sure the connection is tight and always check for leaks. Please see page 14 "Check for Leak" for full instructions.

Check for Leak

Your patio heater has been checked at all factory connections for leaks, but you should always check when you attach the LPG cylinder. To check for leaks, follow these instructions:

- Assemble all gas connections;
 - Connect regulator assembly to the propane tank;
 - Make sure the heater valve is turned OFF.
- 1) Make soapy solution by mixing 1 part liquid dish soap and 3 parts water.
 - 2) Open the propane tank valve.
 - 3) Spoon several drops (or use squirt bottle) of the soapy solution onto the gas hose /regulator and regulator/cylinder connection.
 - 4) Inspect the connections and look for bubbles.
 - 5) If no bubbles appear the connection is safe.
 - 6) If bubbles appear, there is leakage. Close the propane tank valve, and loosen and re-tighten this connection.
 - 7) Check for leakage again.
 - 8) If bubbles still appear and the leak is with the regulator or hose, close the propane tank valve and contact customer support. If a leak is detected, DO NOT attempt to use the heater.

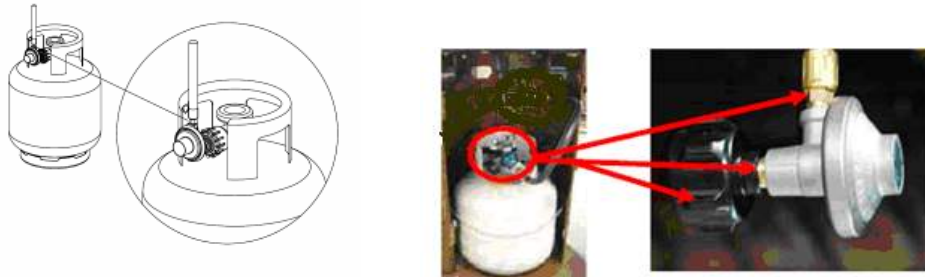

MAKE SURE to check all THREE connections between the cylinder and gas line.

NOTE:

- 1) The cylinder must be provided with a shut off valve terminating in a LPG supply cylinder valve outlet specified, as applicable, for connection NO 510 in the standard for compressed gas cylinder valve outlet and inlet connections, ANSI/CGA-v-1.
- 2) The cylinder supply system must be arranged for vapor withdrawal.
- 3) The cylinder used must include a collar to protect the cylinder valve.

Annually check operation:

- A. Open the front panel of the base assembly.
- B. Open the propane tank valve.
- C. Spoon several drops (or use squirt bottle) of the solution onto gas hose connection and pilot connection.
- D. Inspect the connections and look for bubbles.
- E. If no bubbles appear, the connection is safe.
- F. If bubbles appear, there is a leak. Close the propane tank valve and loosen and re-tighten this connection.
- G. Check for leaks again.
- H. If bubbles still appear, close the propane tank and refer to instructions under #8 on page 14. DO NOT attempt to use the heater.

WARNING: DO NOT attempt to operate the heater until you have read and understand all precautions. Failure to do so can result in serious personal injury, death or property damage.

Before Turning Gas Supply ON.

Your heater was designed and approved for **OUTDOOR USE ONLY**. DO NOT use it inside a building or any other enclosed area.

Make sure surrounding areas are free of combustible materials such as gasoline and other flammable vapors or liquids.

Ensure that there is no obstruction to air ventilation.

Be sure all gas connections are tight and there are no leaks.

Be sure the access panel is clear of debris.

Be sure any component removed during assembly or servicing is replaced and fastened prior to starting.

Before Lighting

Heater should be thoroughly inspected before each use. Have a qualified service person inspect the heater at least annually. If relighting a hot heater, always wait at least 5 minutes.

LIGHTING INSTRUCTIONS

TO TURN ON THE HEATER.

1. Turn the control knob "OFF".
2. Slowly open the gas cylinder valve.
3. Press and turn the control knob to

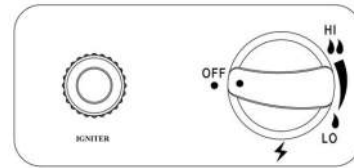

"⚡" position and hold for 30 seconds.

While holding down the control knob, press the igniter several times until the pilot flame ignites. Release the knob after ignition. Note: If the pilot flame does not light or it goes out, repeat Step 3. To regulate the heat, turn the control knob to "LO" position or "HI" position.

4. If the burner flame goes out accidentally or it is blown by wind, turn off the heater and wait at least 5 minutes or more to let the gas dissipate before relighting to avoid gas explosion. Repeat steps 2 to 4.

NOTE:

- If a new tank has just been connected, please allow at least one minute or more for the air in the gas pipeline to purge out through the pilot hole.
- When lighting the pilot flame make sure that the control knob is continuously depressed while pressing the igniter button. Variable control knob can be released after the pilot flame has been lit for 20~30 seconds.
- Pilot flame can be watched and checked from the peephole located on the base of burner.

WARNING
FOR YOUR SAFETY
If at any time you are unable to light burner and smell gas, wait 5 minutes to allow gas to dissipate before attempting to light heater. If after 1 minute you are unable to light burner, wait 5 minutes and allow flammable vapors to dissipate before attempting to light heater again.

TO TURN OFF THE HEATER.

1. Press and turn the control knob to "OFF" position.
2. Turn off the valve on the gas cylinder disconnect the cylinder.

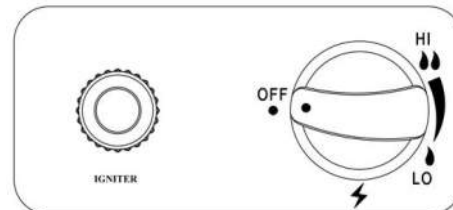

WARNING

Heater will be hot after use. Handle with extreme care.

LOCATION OF HEATER WHILE IN USE

CAUTION: WHEN CERTAIN MATERIALS OR ITEMS ARE LEFT UNDER THIS HEATER WHILE IN USE, THEY WILL BE SUBJECT TO RADIANT HEAT AND COULD BE SERIOUSLY DAMAGED.

This heater is to be used for the heating of outdoor patios, decks, spas, pool, and open working areas. This heater is for outdoor use ONLY.

Always make sure that adequate fresh air ventilation is provided and follow the spacing tolerances shown in the picture below. The minimum clearances must be maintained at all times.

This heater must be placed on level, firm ground.

Never operate in an explosive atmosphere. Keep away from areas where gasoline or other flammable liquids or vapors are stored or used.

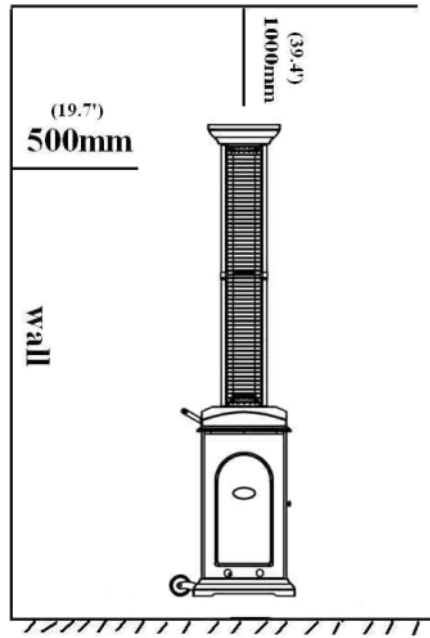

CLEANING AND MAINTENANCE

To enjoy years of outstanding performance from your heater, make sure you perform the following maintenance on a regular basis:

Keep exterior surfaces clean.

1. Use warm soapy water for cleaning. Never use flammable or corrosive cleaning agents.
2. While washing your heater, be sure to keep the area around the burner and pilot assembly dry at all times. If the gas control is exposed to water in any way, DO NOT try to use it. It must be replaced.

Keep the heater area free and clean from combustible materials, gasoline or other flammable vapors and liquids. Visually check burner flames.

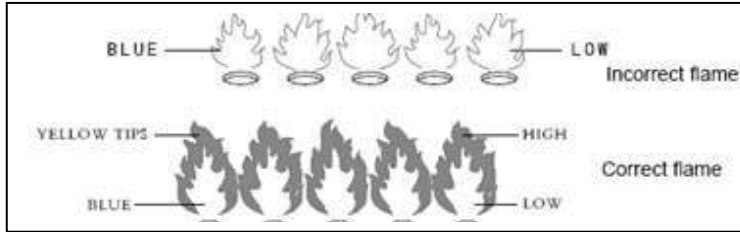

Visually check the hose assembly inside the post and check for any cracks or worn sections.

1. Unscrew gas hose and regulator hose with 3/4" inch open end wrench and adjustable wrench.
2. Check if there are any cracks or worn sections on hose. If yes, contact your gas supplier to replace the hose.
3. At least once a year, the unit should be inspected for the presence of spiders, spider webs or other insects.

Air flow must be unobstructed. Keep controls, burner and circulating air passageways clean. Signs of possible blockage include:

1. Gas odor with extreme yellow tipping of flame.
2. Heater does not reach the desired temperature.
3. Heater glow is excessively uneven.
4. Heater makes uneven popping noise.

Spiders and insects can nest in burner or orifices. This dangerous condition can damage heater and render it unsafe for use. Clean burner holes by using a heavy-duty pipe cleaner. Compressed air may help clear away smaller particles.

Carbon deposits may create a fire hazard. Clean dome and engine with warm soapy water if any carbon deposits develop.

NOTE:

In a salt-air environment (such as near an ocean), corrosion occurs more quickly than normal. If the heater is exposed to this type of environment, you should frequently check for corroded areas and repair them promptly.

TROUBLESHOOTING

Problem	Problem cause	solution
Pilot will not light	Gas valve may be OFF	Turn the gas valve ON
	Tank fuel empty	Refill LP gas tank
	Air in supply system	Purge air from lines
	Loose connection	Check all fittings
Pilot will not stay on	Debris around pilot	Clean dirty area
	Loose connection	Tighten connection
	Thermocouple bad	Replace thermocouple
	Gas leak in line	Check connections
	Lack of fuel pressure	Fuel tank is near empty
Burner will not light	Pressure is low	Fuel tank is near empty
	Control valve not ON	Turn valve to ON
	Thermocouple bad	Replace thermocouple
	Pilot light assembly bent or not in correct location	Place pilot in proper Position and retry
Burner flame goes off immediately after ignition	Low gas pressure	Let the pilot flame stay lit for 10 minutes before setting variable knob to "LO"

Manufacturer: Changzhou Wellife Furnace Co. Ltd.
 Xinqiao Village, Zouqu Town, Wujin District, Changzhou City
 Jiangsu Province, China
 Tel: 86-519-83310111
 Fax: 86-519-83311577
www.globalwellife.com

Distributed By:

Well Traveled Living
716 S 8th Street
Amelia Island, FL 32034
Toll Free: 866-WTL-SUPP



Web: www.wtliving.com
Email: cservice@welltraveled.net

1 YEAR LIMITED WARRANTY – Customers in the Continental US

All components are warranted for a period of 1 year after date of purchase by the original owner against defects in materials and workmanship under normal use. This warranty does NOT cover normal wear and weathering, assembly and/or maintenance OR use in a commercial application. At Well Traveled Living's sole discretion, products under warranty will be repaired and/or replaced at no charge to the customer. Any returns sent back to Well Traveled Living must be sent via prepaid freight and in the original retail packaging.

For warranty service contact Well Traveled Living at the address, phone numbers or internet site and email listed in this owner's manual. Be sure to have your sales receipt, date of purchase and catalogue/model numbers available when calling. All warranty service will be coordinated by the Well Traveled Living's, Amelia Island, Florida service center.

This warranty is extended only to the original purchaser. Proof of purchase will be required before warranty service is rendered. The sales receipt is the only valid proof of purchase. This warranty only covers failures due to defects in materials or workmanship which occur during normal use. Failures and/or damage which result from accident, negligence, misuse, abuse, neglect, mishandling, alteration or modification, failure to maintain, improper assembly or maintenance, service by unauthorized agency or use of unauthorized components or damage that is attributable to acts of God are NOT covered.

*****THERE ARE NO EXPRESS WARRANTIES EXCEPT AS LISTED ABOVE*****

*****PURCHASER ASSUMES ALL RISKS IN THE ASSEMBLY AND OPERATION OF THIS UNIT*****

*****FAILURE TO FOLLOW WARNINGS AND OPERATIONAL INSTRUCTIONS CONTAINED IN THIS MANUAL CAN RESULT IN SEVERE PROPERTY DAMAGE AND/OR PERSONAL INJURY*****

IN NO EVENT WILL WELL TRAVELED LIVING, OR ITS DIRECTORS, OFFICERS OR AGENTS BE LIABLE TO THE PURCHASER OR ANY THIRD PARTY, WHETHER IN CONTRACT, IN TORT, OR ON ANY OTHER BASIS, FOR ANY INDIRECT, SPECIAL, PUNITIVE, EXEMPLARY, CONSEQUENTIAL, OR INCIDENTAL LOSS, COST, OR DAMAGE ARISING OUT OF OR IN CONNECTION WITH THE SALE, MAINTENANCE, USE, OR INABILITY TO USE THE PRODUCT, EVEN IF WELL TRAVELED LIVING OR ITS DIRECTORS, OFFICERS OR AGENTS HAVE BEEN ADVISED OF THE POSSIBILITY OF SUCH LOSSES, COSTS OR DAMAGES, OR IF SUCH LOSSES, COSTS, OR DAMAGES ARE FORESEEABLE. IN NO EVENT WILL WELL TRAVELED LIVING, OR ITS OFFICERS, DIRECTORS, OR AGENTS BE LIABLE FOR ANY DIRECT LOSSES, COSTS OR DAMAGES THAT EXCEED THE PURCHASE PRICE OF THE PRODUCT.

SOME JURISDICTIONS DO NOT ALLOW THE EXCLUSION OR LIMITATION OF INCIDENTAL OR CONSEQUENTIAL DAMAGES, SO THE ABOVE LIMITATION OR EXCLUSION MAY NOT APPLY TO THE PURCHASER.

This limited warranty gives you specific legal rights and you may also have other rights which vary from jurisdiction to jurisdiction. The provisions of the United Nations Convention on Contracts for the Sales of Goods shall not apply to this limited warranty or the sale of products covered by this limited warranty.

*****IMPORTANT NOTICE*****

-Do **NOT** return to place of purchase-
For customer service and warranty issues
contact our Customer Service Center at:
(866)-985-7877 OR

Email: cservice@welltraveled.net

Customer Service Hours: Mon. – Fri. 9:00 a.m. – 6:00 p.m. (EST)