

BAYSIDE

12 Ft x 4 Ft

MODEL B124

MODEL SPECIFIC INSTRUCTION MANUAL

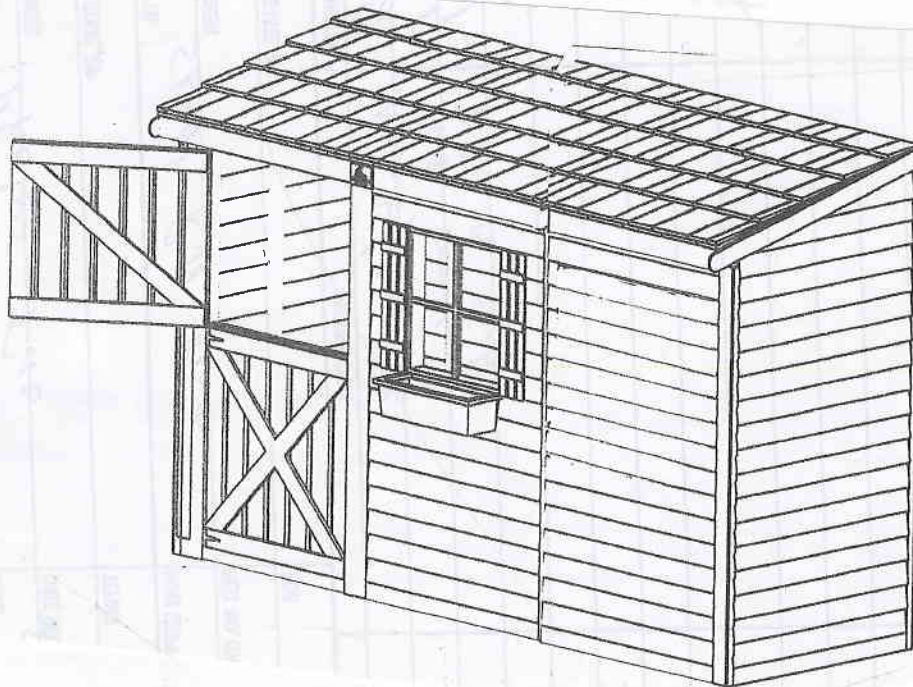

ACCESSORIES AND HARDWARE

B124

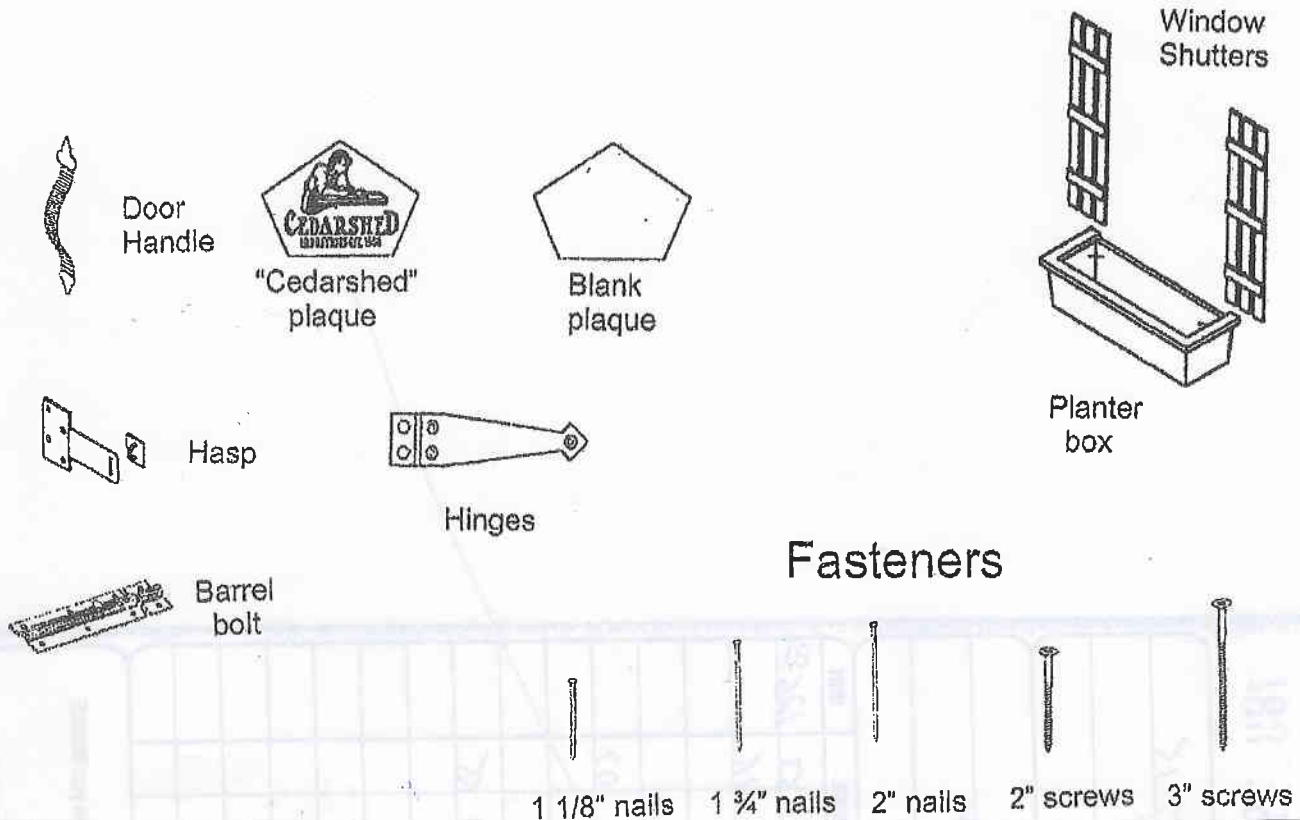

Part Number	Part Name	Size or Type	No.
ACCESSORIES			
P-H-PLAQL	Cedarshed plaque		1
P-SH - 001	Window shutters		2
P-FW - 001	Flower box		1
P-H - MFLASS	Metal roof flashing	3" x 12"	15
Part Number	Part Name	Size or Type	No.
FASTENERS			
P-H - SC2	2" screws	Bag	75
P-H - SC3	3" screws	Bag	250
P-H - NL 1.75	1 3/4" finishing nails	Bag	260
Part Number	Part Name	Size or Type	No.
DOOR HARDWARE			
DR - 003	Dutch Door		1
P-H - HASP	Hasp		1
P-H - DHAND	Door handles		1
P-H - THING6	Door hinges		4
P-H - BBLT4	Barrel bolt		1
Instruction manual, questionnaire and driver bit			

* door trim-narrow to be used when door is located on 8 ft side/
wide to be used when door is located on 4 ft side.

FOUNDATION PREPARATION

PREPARE THE SITE:

Before you begin assembly, clear the construction area. Remove all organic material such as roots grass, dirt and large rocks that may compromise the ability to level the site. Make sure the ground slopes away from the site at least 10 ft. (3.05 m.) in all directions. If necessary, build up the centre of the site and slope away from the high point to provide drainage. Fill in any low spots within the perimeter of the site. Be sure to use gravel or a good packing material to level the site. Make sure it is packed down before beginning the building process.

FIUNDATION CHOICES:

1. Concrete Patio Stones (not included)

If the ground is stable and has sufficient drainage, you can set patio stones directly on a firm compacted gravel base. Make sure the stones are thick enough to allow air circulation under the structure. This helps to prevent dry rot from setting in on the joist. The bearing points are outlined in the next page of this manual.

2. PRESSURE TREATED WOOD STRINGERS (not included)

A second option is to use 4x4 (90 mm x 90 mm) stringers which can run the full width of the structure. Be sure to use a stringer every 4 ft. For example for an 8x12 floor structure, you will need 4-8 ft. stringers. This reduces the amount of leveling needed as you only need to level each end of the stringer. However, it will increase the height of the shed and you may require a ramp or an additional step at the doorways.

3. CONCRETE SLAB

Typically a slab 3"-4" (75 - 102 mm) thick laid over a subbase of 4" (102 mm) of gravel or crushed rock is sufficient but may vary (consult your local Home Centre). Either mix your own concrete or have it delivered to your site. A 10' x 10' x 4" (3.05 m. x 3.05 m. x 10.2 cm.) slab will require approximately 1 cubic yard (0.764 cubic metre) of concrete. In any case, make sure you excavate the slab area to a depth of 6" (15.2 cm.), use 4" (10.2 cm.) of gravel as your subbase. Welded wire mesh as reinforcing (optional) and 4" (10.2 cm.) of concrete (trowel to allow for drainage away from the centre high point). Still use 1" (2.54 cm.) thick patio stones on the concrete slab to allow adequate air circulation to keep the floor joist dry. This will prevent dry rot from setting in.

4. POURING CONCRETE PIER POINTS USING SAUNA TUBES

Another option would be the pouring of concrete pier points using sauna tubes. Using the next page as a guide, place sauna tubes into the ground at each of the bearing points. Make sure the tops of the sauna tubes are level with the other. You may also wish to inbed metal straps into the concrete. These straps will be nailed to the joist structure.

1. Foundation Preparation

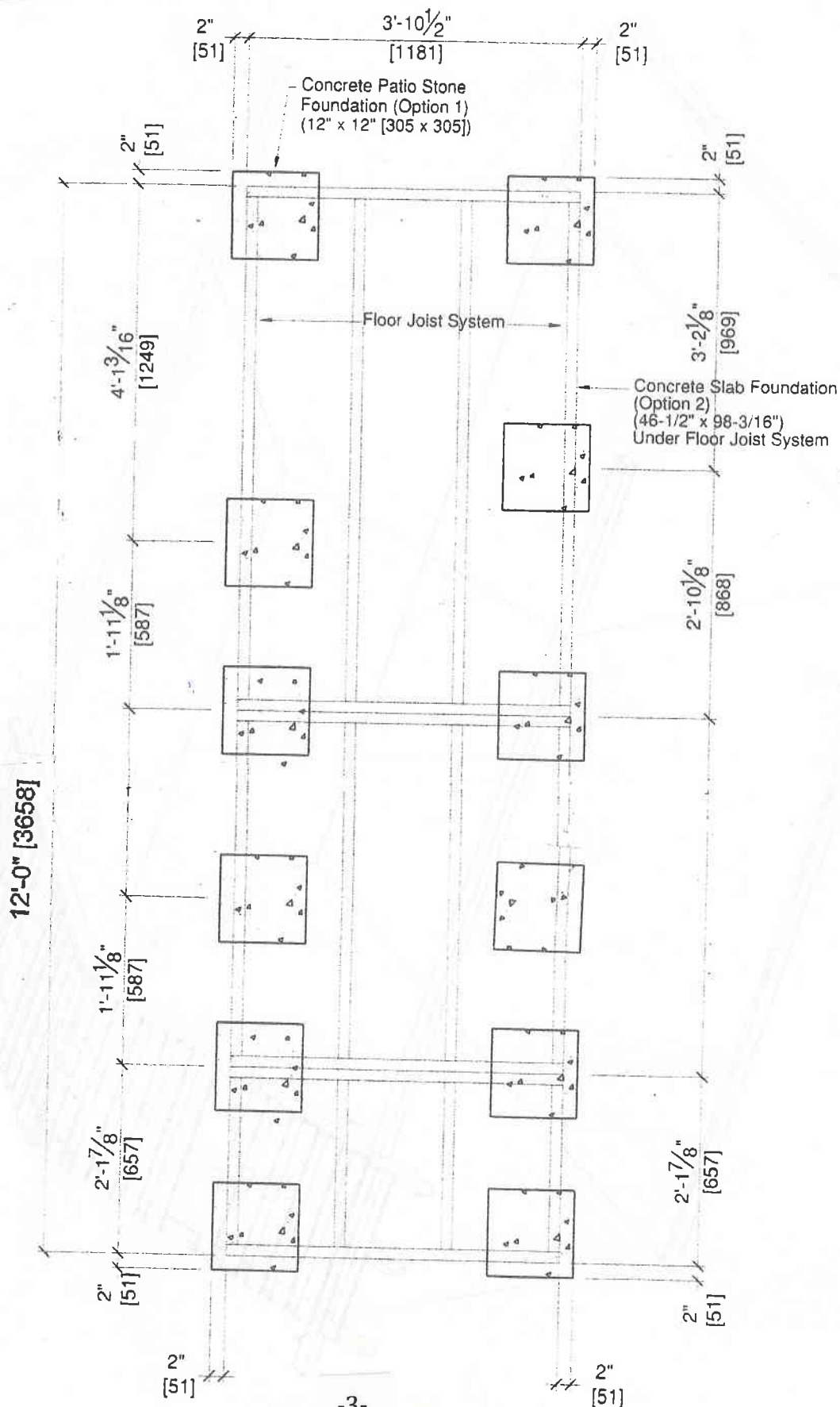

6x9 OSB Ply

FOUNDATION PREPARATION

1. Use a 2x3 or 2x4 straight piece of lumber on edge and a carpenter's level to level the perimeter patio stones. Add or remove soil under each stone until it is flush with the bottom of the 2x4 as shown in Fig. 1. Continue this procedure with the stones until you are satisfied all the stones are level with one another.

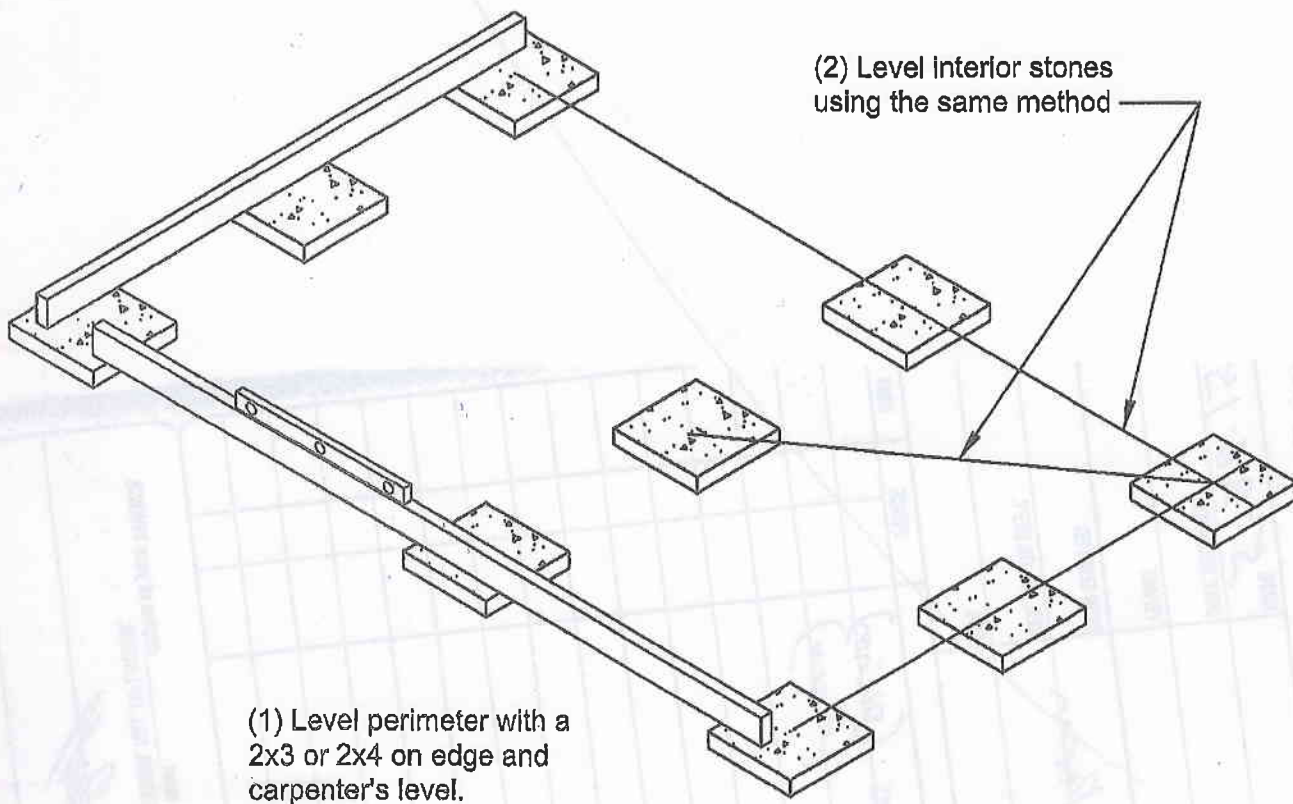

BAYSIDE 12X4

Fig. 1

Part Number	Part Name	Size or Type	No.	CODE
FLOOR PARTS				
P-2423	Floor Joist	2 x 4 x 23"	4	
P-2443G	Floor Joist	2 x 4 x 43 1/2"	4	
P-2446G	Floor Joist	2 x 4 x 46 1/2"	6	
P-2469	Floor Joist	2 x 4 x 69"	4	
P-PL-I2446G	Plywood Sheet	5/8 x 24 x 46 1/2"	3	
P-PL-I2646G	Plywood Sheet	5/8 x 26 x 46 1/2"	1	
P-PL-I46G46G	Plywood Sheet	5/8 x 46 1/2 X 46 1/2"	1	

46 1/2" x 46 1/2" Joist Box - P9

Revised 12/22/10

JOIST BOX ASSEMBLY

Lay the joist parts out as per Fig. P9-1. Using 2- 3" screws per joint, assemble the joist box together as per Fig P9-2. The completed joist box is pictured in Fig. P9-3.

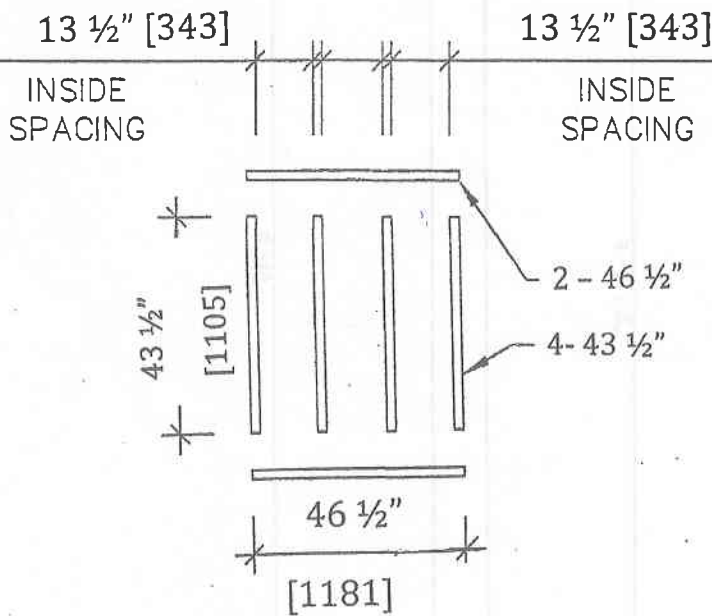

46 1/2" x 46 1/2" joist box layout

Fig P9-1

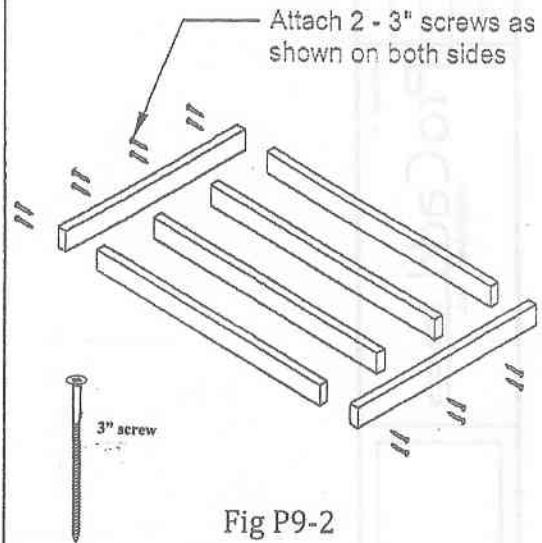

Fig P9-2

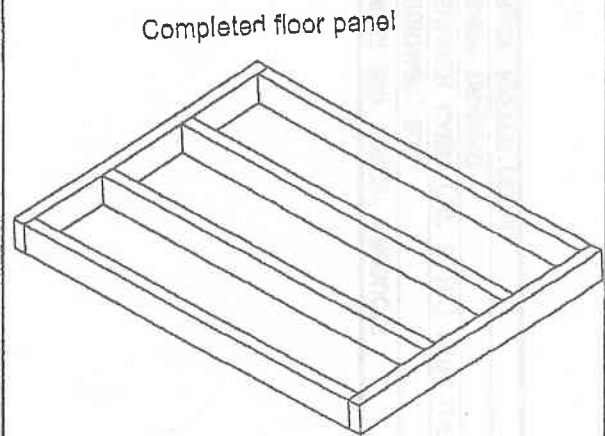

Fig P9-3

46 1/2" X 26" Joist Box - P12

B124

JOIST BOX ASSEMBLY

Lay the joist parts out as per Fig. P12-1. Using 2-3" screws per joist assemble the joist box together as per Fig 12-2. The completed joist box is pictured in Fig. P12-3.

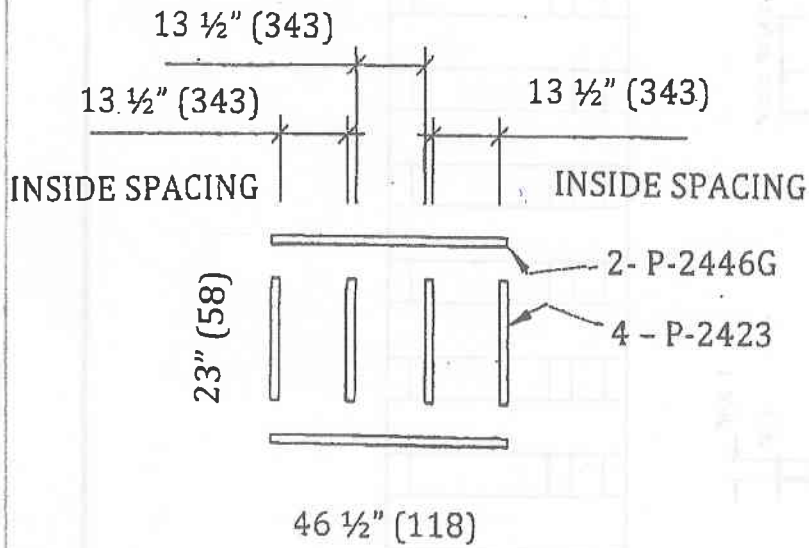

46 1/2" x 26" floor panel layout

Fig P12-1

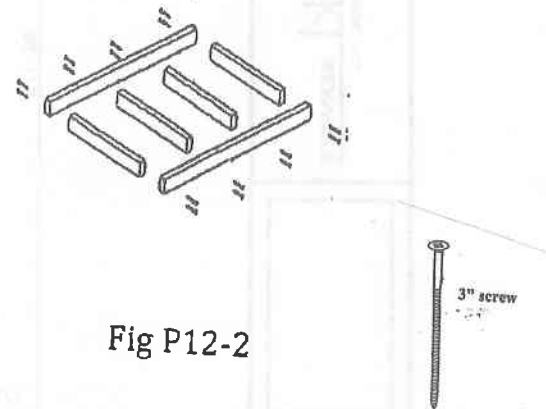

Fig P12-2

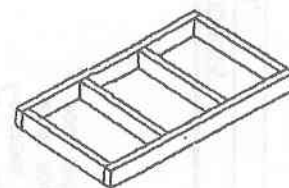
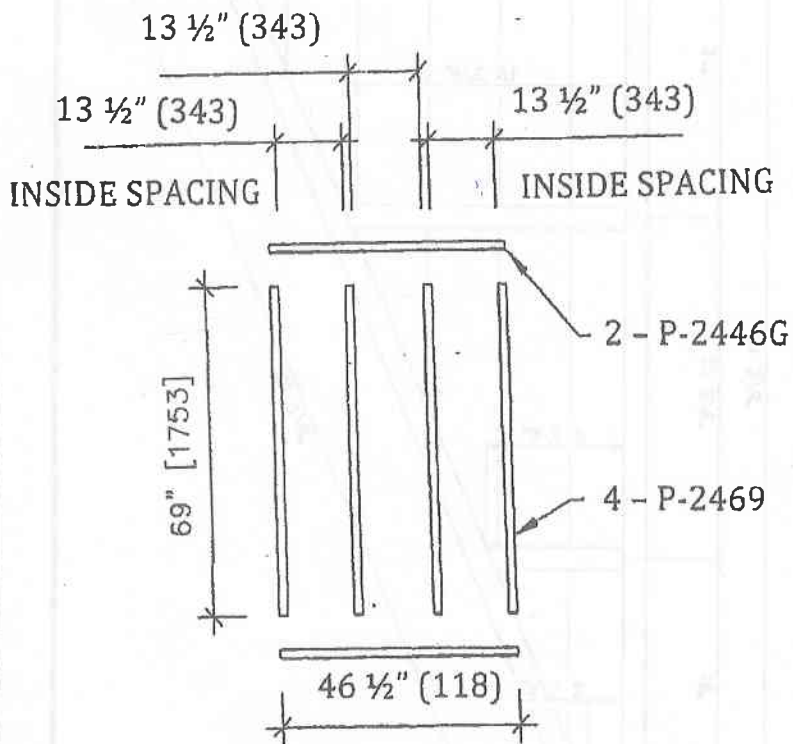

Fig. P12-3

46 1/2" X 72" Joist Box - P11

JOIST BOX ASSEMBLY

Lay the joist parts out as per Fig P11-1. Using 2-3" screws per joist assemble the joist box together as per Fig. P-11-2. The completed joist box is pictured in Fig. P11-3



46 1/2" x 72" floor panel layout.

Fig P11-1

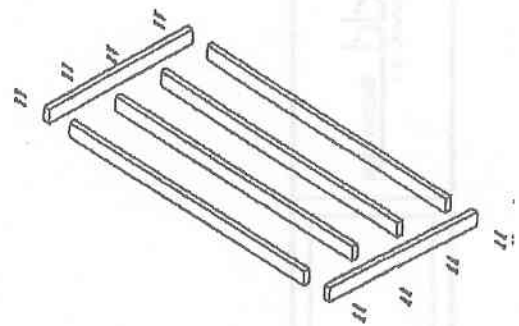

Fig P11-2

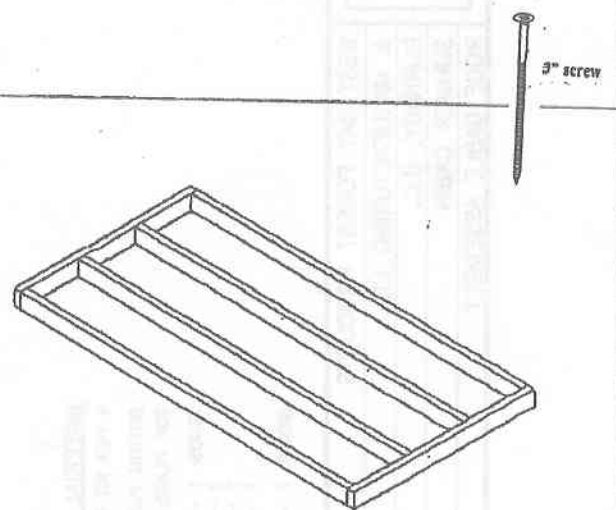
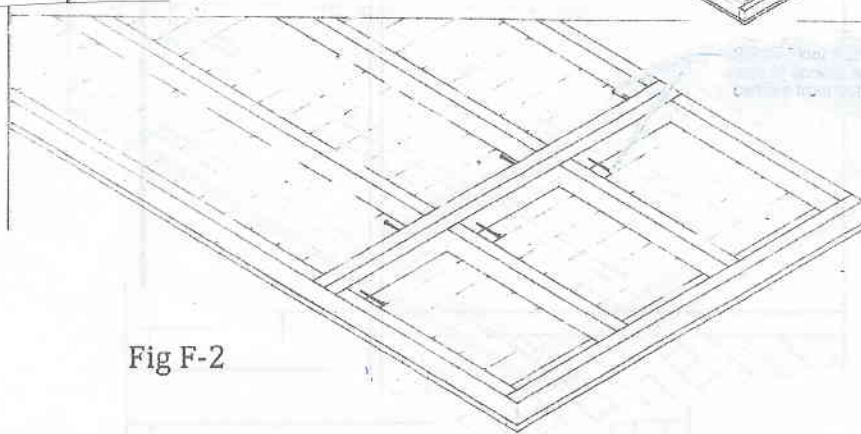
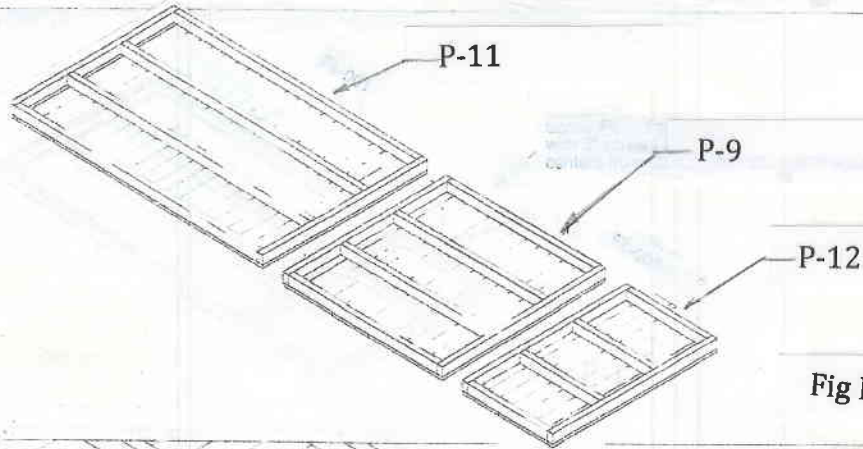

Fig. P11-3

FLOOR ASSEMBLY

B124

Attach P-11, P-9, and P-12 joist boxes together using 6-3" screws. Please refer to Fig F-1 and Fig F-2 for details.



Affix the plywood panels as per Fig. F-3 using 2" screws on 12" and affixing the plywood to each row of joist. The finished floor is shown in Fig F-4.

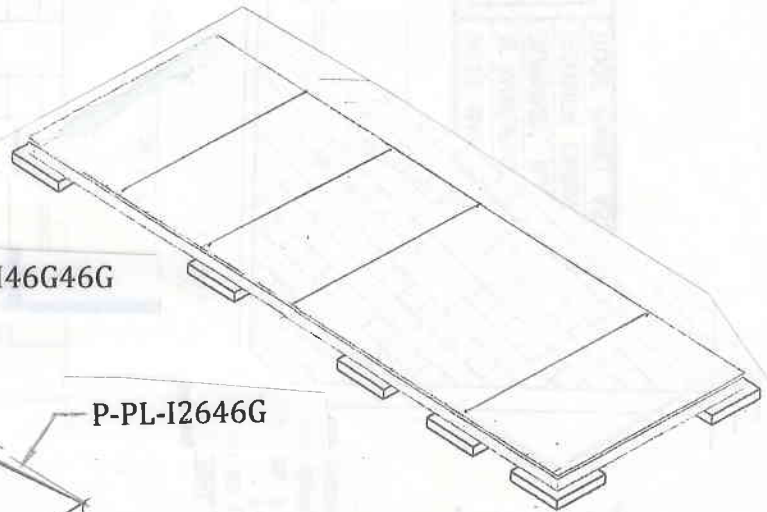
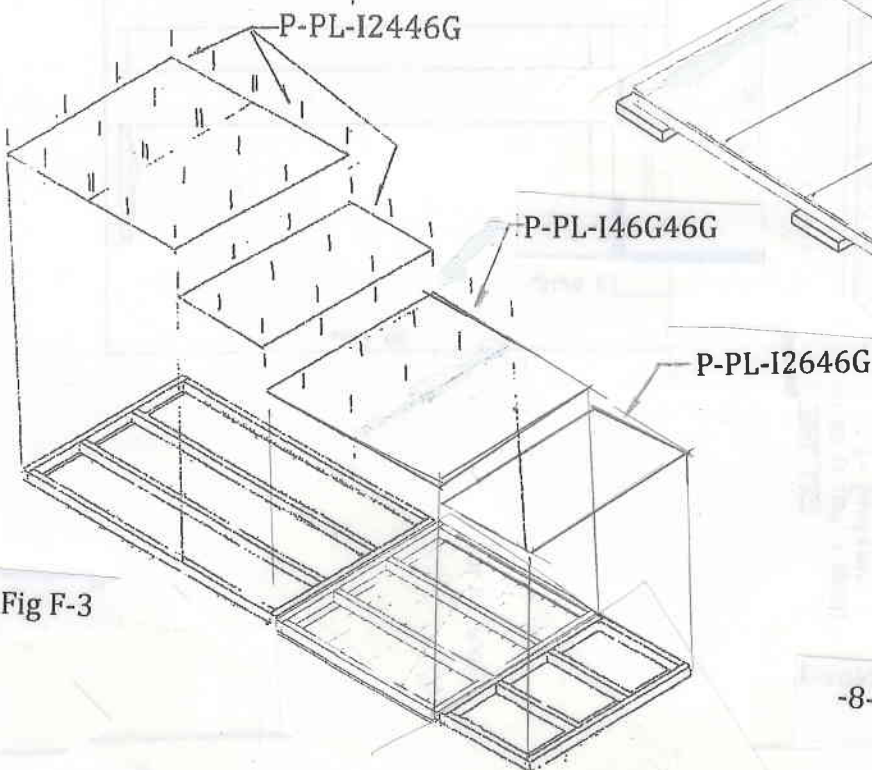

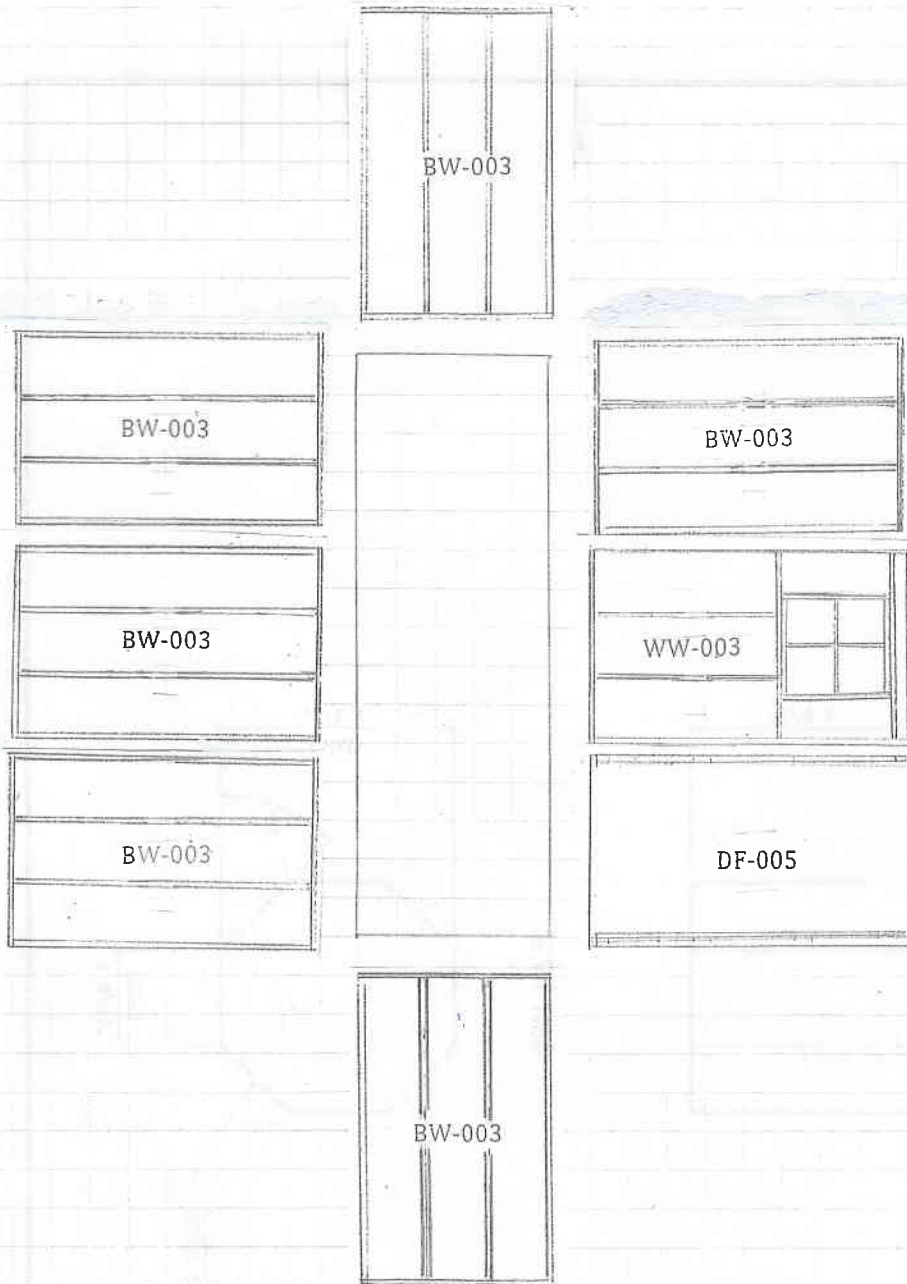

Part Number	Part Name	Size or Type	No.	CODE
WALL PARTS AND PANELS				
P-2346G	Headers	2 x 3 x 46 1/2"	6	not shown
BW-003	Solid wall panel	46 1/2 x 73 1/4"	6	BW-003
WW-003	Window wall panel	46 1/2 x 74 3/4"	1	WW-003
DF-005	Door Frame	48 x 73 1/4"	1	DF-005

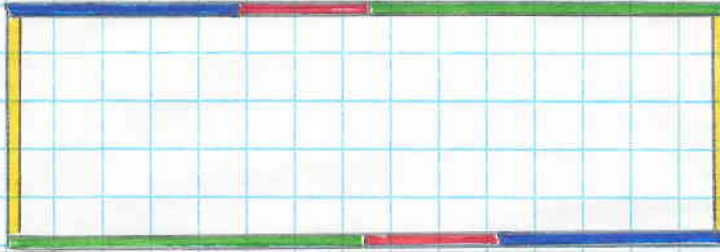

Part Number	Part Name	Size or Type	No.	CODE
TOP PLATES				
P-2341G	Top plates	2 x 3 x 41 1/2"	2	
P-2346G	Top plates	2 x 3 x 46 1/2"	2	
P-2371K	Top plates	2 x 3 x 71 3/4"	2	
P-2326C	Top plates	2 x 3 x 26 1/4"	2	

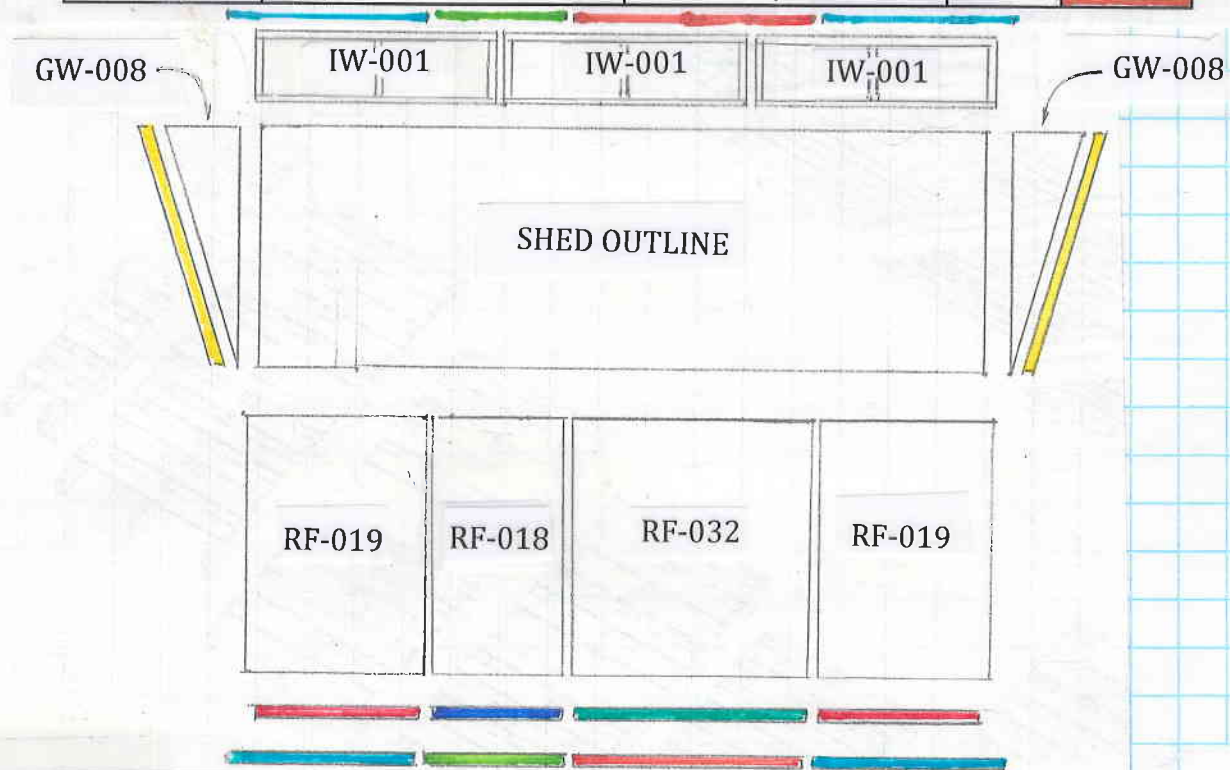

Part Number	Part Name	Size or Type	No.	CODE
ROOF PARTS AND PANELS				
GW - 008	Gable panel	9 x 51 5/8"	2	GW-008
IW-001	Infill wall panel	46 1/2 x 9 1/4"	3	IW-001
RF-018	Roof panel	24 x 51 5/8"	1	RF-018
RF - 019	Roof panel	42 3/4 x 51 5/8"	2	RF-019
RF-032	Roof panel	46 1/2 x 51 5/8"	1	RF-032
P-B-G446G	Soffits	1/2 x 4 x 46 1/2"	1	
P-B-G424	Soffits	1/2 x 4 x 24"	1	
P-B-G437	Soffits	1/2 x 4 x 37"	2	
P-1446G	Fascia	1 x 4 x 46 1/2"	2	
P-1424	Fascia	1 x 4 x 24"	2	
P-1442	Fascia	1 x 4 x 42"	4	
P-1455Yg	Gable Fascia	1 x 4 x 55"	2	

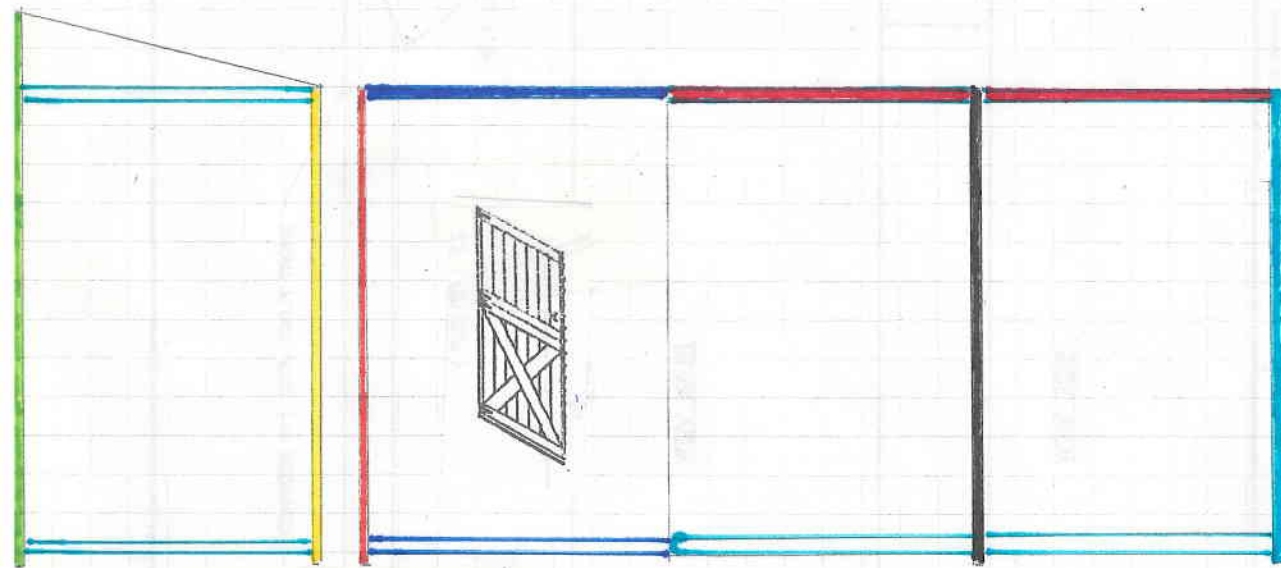
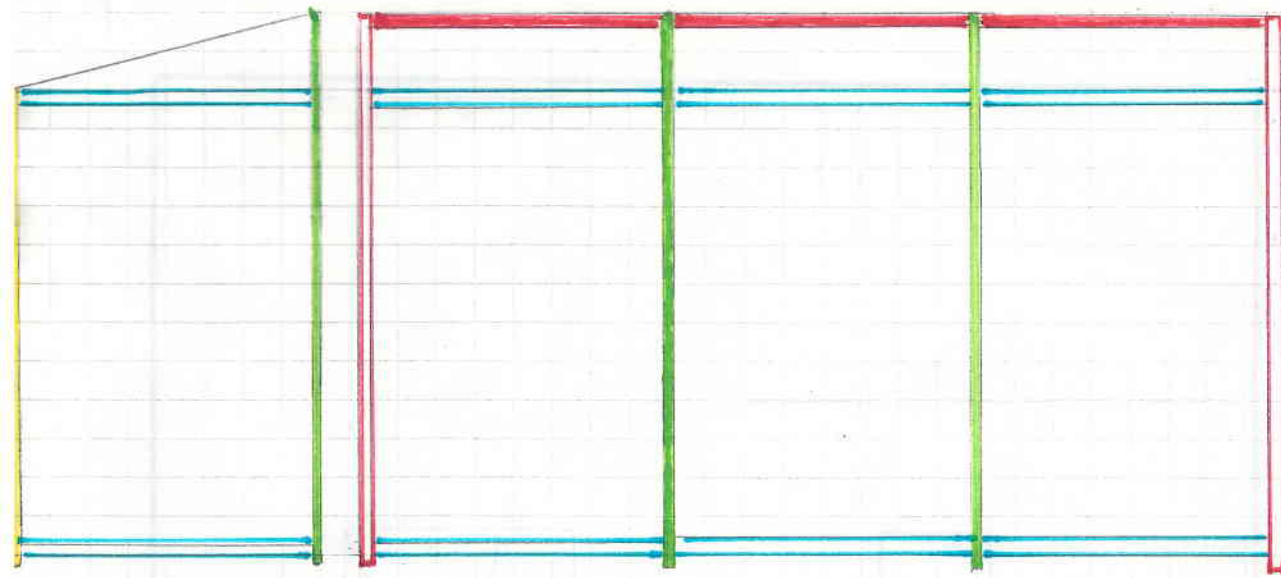

Part Number	Part Name	Size or Type	No.	CODE
TRIMS PARTS				
P-1280G	Trim (short)	1 x 2 x 80 1/2"	2	
P-1279C	Trim (short)	1 x 2 x 79 1/4"	1	
P-11K79C	Trim (short)	1 x 1 3/4 x 79 1/4"	1	
P-13C79C	Trim (short)	1 x 3 1/4 x 79 1/4"	1	
P-1289G	Trim (long)	1 x 2 x 89 1/2"	4	
P-13C89G	Trim (long)	1 x 3 1/4 x 89 1/2"	2	
P-B-G645	skirting	1/2 x 6 x 45"	12	
P-B-G445	skirting	1/2 x 4 x 45"	5	
P-11K48	top door trim (narrow)*	1 x 1 3/4 x 48"	1	
P-1348	top door trim (wide)*	1 x 3F x 48"	1	no code
P-B-14B48	door skirting	1 x 4 1/8 x 48"	1	

* door trim-narrow to be used when door is located on 8 ft side/
wide to be used when door is located on 4 ft side.